

# OWNER'S MANUAL

## PIPECOATER-I AND PIPECOATER-II INTERNAL PIPE PAINTING TOOL

### IMPORTANT WARNING FOR SAFER BLAST CLEANING

1. Use protective equipment: Abrasive-resistant clothing, safety shoes, leather gloves, ear protection, CE-approved air-fed helmet. Air for helmet must be supplied by a breathing air compressor or through a helmet air filter.
2. Check for possible silicosis hazards. Avoid dust.
3. Do not blast with damaged or worn equipment.
4. Point nozzle only at area being cleaned.
5. Use only proper dry and well-screened abrasives specifically intended for blasting.
6. Keep unprotected workers out of the blast area.
7. Before blasting:
  - Check fittings and hose for wear.
  - Safety-wire couplings together.
  - Check helmet filters and air supply.
  - Check pop-up valve for alignment.
  - Test remote controls.
  - Make sure blast machine is adequately grounded.
8. Do not weld on blast machine, this voids approval.
9. Do not substitute Blastrite parts or modified equipment in any way.



Servicing your blasting  
and painting needs

08600 BLAST  
sales@blastrite.co.za

 [www.blastrite.com](http://www.blastrite.com)

## PIPECOATER-I, PIPECOATER-II

**1.0 INTRODUCTION:** PIPECOATER tools are designed to coat the inside of pipe or tubing without the need to rotate pipe or tubing and to apply an even paint film thickness throughout. Generally, any type of coating may be used in this tool that can be airless sprayed. To obtain the best possible production, one man should operate the Control Gun while another man pulls the tool through the pipe or tubing.

**1.1 NOTE:** BE SURE TO CHECK WITH THE COATING MANUFACTURER OR SUPPLIER ON THE SIZE SPRAY TIP TO BE USED FOR APPLYING THE TYPE OF COATING SPECIFIED. SPRAY TIP SIZES USED ON PIPECOATER ARE NORMALLY LARGER THAN TIP SIZES USED FOR HAND SPRAYING APPLICATIONS. IMPROPER SPRAY TIP MAY EFFECT SPEED AND PAINT THICKNESS. THE PIPECOATER-I IS SUPPLIED WITH A .026 SPRAY TIP AS STANDARD. PIPECOATER-II HAS A .036 SPRAY TIP. ANY NORMAL AIRLESS PAINT SPRAY PUMP MAY BE USED WITH THE PIPECOATER TOOLS, HOWEVER, THE MINIMUM PRESSURE RATIO SHOULD BE 30:1. FOR BEST RESULTS, USE AN AIRLESS PUMP WITH A RATIO OF 45:1 AND A CAPACITY OF 2.5 U.S. GALLONS PER MINUTE. SPRAY TIP IS LOCATED IN PAINT FEED TUBE ASSEMBLY ON THE PIPECOATER TOOL. (SEE FIGURE 2, ITEM 14 AND FIGURE 3, ITEM 43).

**1.2** Air requirement for PIPECOATER is 15 CFM at 95 to 100 psig (400 Litre/Min at 7 BAR). Air requirement for PIPECOATER-II is 22 CFM at 95 to 100 psig (600 Litre/ Min at 7 BAR). PIPECOATER-I is designed to coat inner diameters from 4" to 6" (90mm to 155mm). PIPECOATER-II handles 7" to 37" (180mm to 950mm).

### IMPORTANT WARNING

**HIGH PRESSURE DEVICE: HIGH PRESSURE CAN CAUSE SERIOUS INJURY. SAFETY PRECAUTIONS SHOULD BE TAKEN WHILE SERVICING OR OPERATING HIGH PRESSURE EQUIPMENT.**

**A.** Before operating any part of the PIPECOATER system, be sure to check all fittings and connections for tightness. Immediately replace any damaged or worn parts.

**B.** Use only high pressure hose and fittings designed for use with this equipment. Do not substitute any parts as it will void warranty and may be unfit for this application.

**C.** Never exceed specified airless pump or compressed air pressures.

**D.** Keep hands clear of centering legs to prevent injury.

**E.** Before making any adjustments, repairs, etc., shut-off airless pump and air compressor. Release fluid pressure from all lines.

**F.** If disassembled from system, never point paint spray gun at any person. The high velocity paint is dangerous.

**G.** Always engage spray gun safety lever when gun is not in use.

**H.** Refer to Airless Pump Instruction Sheet for additional safety precautions.

**I.** Always maintain a distance of 10 feet from rotating head while paint is flowing.

**2.0 INSTALLATION:** Connect high pressure paint hose to spray gun connector and to PIPECOATER paint hose fitting. Check that correct spray tip is in place and the in-line strainer is clean and in good condition. (See Photo A and B) Tighten all high pressure paint hose fittings with a wrench.

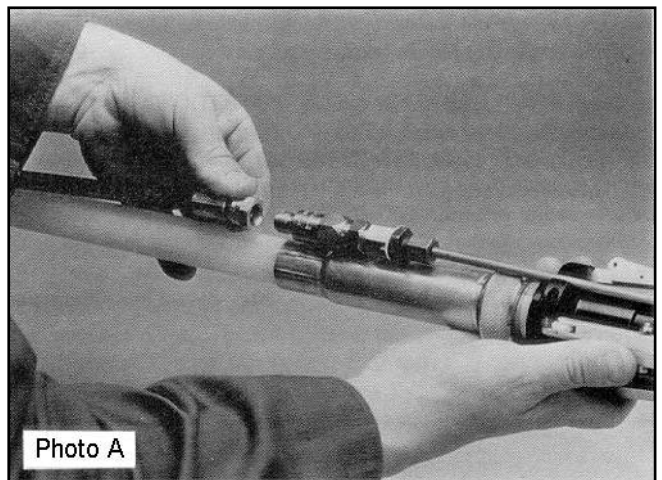

Photo A

## PIPECOATER-I, PIPECOATER-II

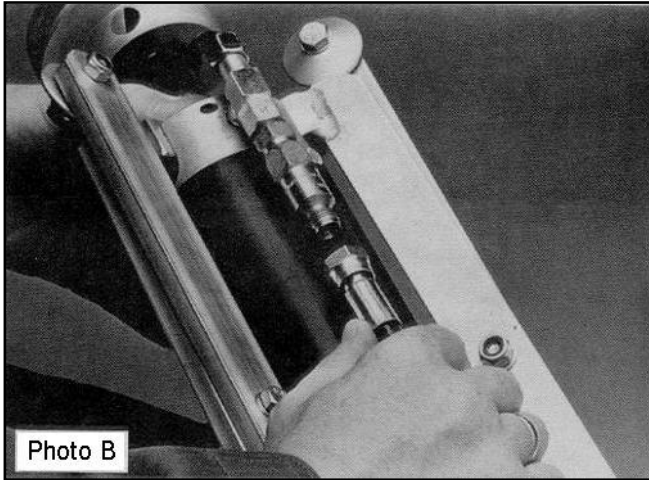

Photo B

**2.3** Attach Air Control Hose to PIPECOATER air inlet port and Control Gun Assembly air outlet port. Use care in attaching Air Control Hose to avoid damaging O-rings. A drop of oil or grease applied to the O-rings will ease attachment. If an O-ring is damaged, it must be replaced immediately to ensure proper seal. Air Control Hose is available in three lengths: 10 ft., 16 ft. and 32 ft. (3m, 5m, and 10m). Hose is purchased separately in lengths to suit specific applications. Various lengths may be connected together to obtain desired overall length. Airless spray pump performance and paint hose distance capability must be considered with regard to pressure drop in paint hose. Maximum air control hose distance between PIPECOATER and control gun assembly is 64 ft. (20m). (See Photo C, D and E).

**2.4** Attach compressed air hose (not supplied) to threaded fitting located at the back of the Air Control Assembly. (See Photo F.) Air inlet fitting is 1/4" (6 mm) pipe thread, but air hose I.D. should be a minimum of 1/2" (13 mm) to ensure sufficient pressure and volume of air is available to operate air motor and centering legs.

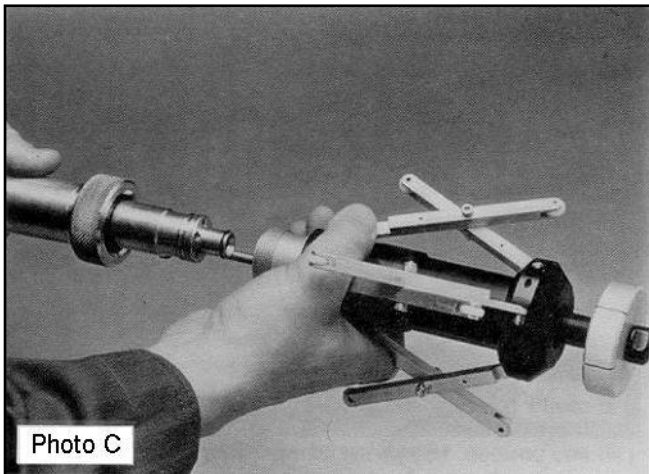

Photo C

**2.5** Connect high pressure paint hose from airless pump to hose fitting on spray gun. (See Photo F.)

Follow airless pump manufacturers instructions on setting up spray pump. Check all connections for tightness.



Photo D

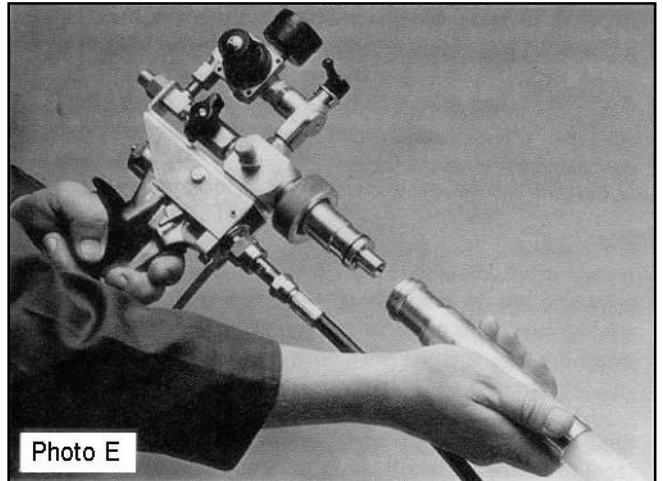

Photo E

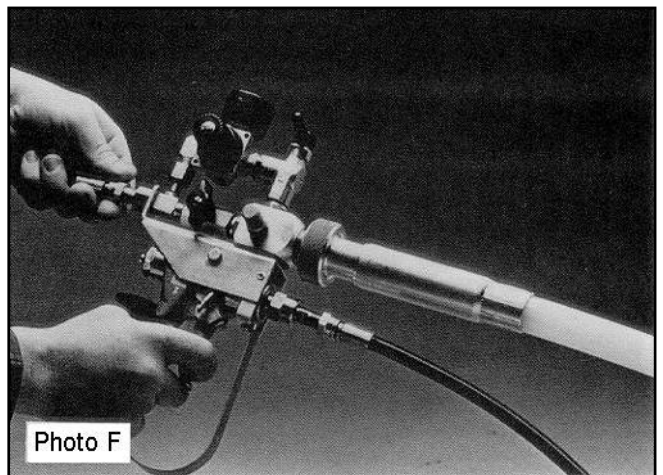

Photo F

### IMPORTANT WARNING

**TURN ON AIR COMPRESSOR AND CHECK PRESSURE. DO NOT EXCEED 100 PSIG (7 BAR).**

## PIPECOATER-I, PIPECOATER-II

**2.6** If using PIPECOATER-II, centering legs supplied will be installed to work in diameters from 11" to 37" (260mm to 950mm). To adapt the unit to cover 7" to 11" (180mm to 260mm), remove outer section of legs and reattach wheels to inner section.

**2.7** Unit is now ready for test and operation.

---

**3.0 OPERATION:** Before starting actual painting, it is advisable to operate the PIPECOATER without paint in order to become familiar with the handling of the unit.

**3.1** Turn on the Start/Stop Knob (Figure 1, Item 6) to check the spin of the rotating head.

**3.2** Set the air pressure on the pressure regulator at 100 psig (7 BAR). See Figure 1, Item 2.

**3.3** The air valve lever (Figure 1, Item 9) operates the centering carriage. Be sure the carriage legs are clear of any obstacles before turning the lever. Do not put hands on the carriage or its legs when expanding or retracting the carriage legs. Serious injury may occur if fingers are caught between the legs.

**3.4** Air valve lever, when fully opened, expands legs until forced against inner diameter of pipe. To relax tension of legs, reduce air pressure using the regulator. Adjustment of leg tension may be necessary when approaching bends or protrusions in pipe. Adjustment pressure varies due to degree of bend, size of protrusion and diameter of pipe. If carriage fails to open fully, a gentle lift on the PIPECOATER body will assist leg expansion. In order to operate carriage legs properly, the leg positioned on the bottom of the pipe must be set straight up and down. When viewing the PIPECOATER in the pipe, the carriage should appear in the shape of a "Y".

**3.5** To retract carriage, close air valve lever.

**3.5.1** At this point, airless spray pump should be checked for tight fittings and proper pressure setting.

**3.5.2** Before inserting PIPECOATER into pipe, position rotating head inside a container and squeeze

spray gun trigger. When satisfied with paint flow, pipe spraying may begin.

**3.6** Check pipe interior to ensure that it is clean and ready for coating.

**3.7** Insert PIPECOATER into pipe making sure that one leg is directly on the bottom of the pipe. Extend carriage legs and check proper positioning of legs. Push PIPECOATER through pipe until rotating head is flush with the pipe edge on the opposite end. Always pull PIPECOATER through pipe. Avoid pushing tool back as carriage wheels will damage wet coating, Re-check carriage leg tension to be sure carriage can be pulled at a smooth and steady rate.

**3.8** Turn on Start/Stop Knob (Figure 1, Item 6) to spin rotating head. Squeeze spray gun trigger to begin paint flow. Release trigger immediately if carriage movement is interrupted. It is critical that the operator pulling the PIPECOATER hose move the tool through pipe at even rate to avoid excessive paint thickness. Speed of tool movement varies with pipe diameters. Small pipes can be painted faster than larger pipes. If two or more coats are desired, allow each coat to dry sufficiently prior to applying the next coat. Refer to paint manufacturers instructions for accurate drying time.

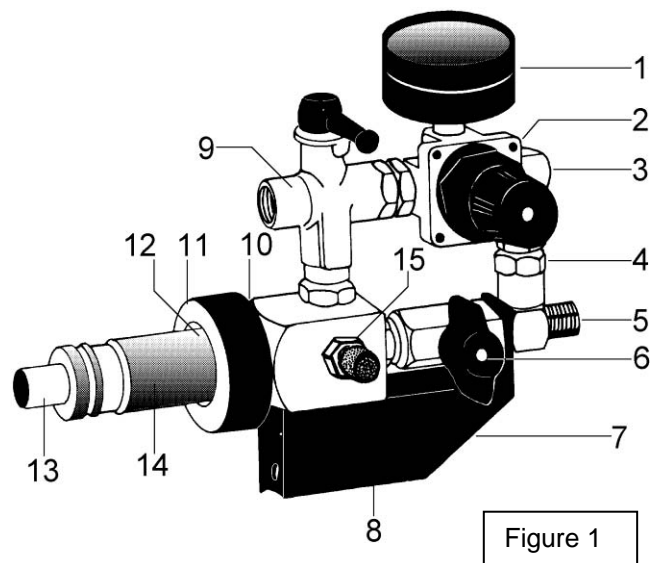

**3.9** At the exit end of pipe, furnish a shield to capture overspray as tool leaves the pipe. Use extreme care when removing PIPECOATER from end of pipe. First, be sure no one is within 10 feet of rotating head except the operator. Second, be careful when handling the tool as it leaves the pipe. Legs may expand when disengaged from pipe. Release spray gun trigger and shut-off rotating head knob when tool is removed from pipe.

## PIPECOATER-I, PIPECOATER-II

**3.10** Turn off air compressor and relieve all fluid pressure from the system including airless spray pump.

---

### **4.0 MAINTENANCE:**

**4.1** When painting is finished, promptly clean the PIPECOATER carefully. Do not allow paint to dry in any of the internal PIPECOATER or spray gun parts. Place rotating head in a container and run solution through paint hose. Turn on rotating head knob to allow solvent to flush out spray gun, paint hose, spray tip and rotating head. When clear solvent is evident on the rotating head, tool has been cleaned sufficiently. Use only cleaning solvents that are recommended by the paint manufacturer.

#### **IMPORTANT WARNING**

**NEVER SUBMERGE PIPECOATER TOOLS IN ANY TYPE OF SOLVENT. DAMAGE WILL OCCUR TO GASKETS AND SEALS.**

**4.2** Remove strainer housing (Figure 2, Item 13 and Figure 3, Item 44), disassemble and clean strainer with solvent. Reassemble making sure nylon ring seal is in place. Use pipe thread tape to ensure a good seal when replacing strainer housing. Never allow paint to dry anywhere in the system.

**4.3** Remove rotating head and clean internal cavity of disc with solvent. Any build up of paint will have an adverse effect on uniform paint flow.

**4.4.** Lubrication of the PIPECOATER is important. Daily, supply 5 to 10 drops of lightweight oil through the air inlet on the PIPECOATER. If air compressor is fitted with an oil mist lubricator, be sure the oil cup is full of lightweight oil (SAE 10, Mobile Spindle Oil No. 1, Shell Spindle Oil 60 or equivalent).

**4.5** Use extra care on handling of air control hose. Sharp bends or crushed hose may damage the two internal hoses which could effect tool performance. Always store hose where it may be kept as straight as possible. Replace protective caps on Air Control Hose to prevent damage to precision threads.

**4.6** Follow manufacturers instructions on cleaning airless spray pump.

## PIPECOATER-I, PIPECOATER-II

---

### 5.0 TROUBLESHOOTING

PROBLEM	CAUSE	REMEDY
Rotating head does not spin when air is applied.		<p>Check air supply is connected to control gun.</p> <p>Check that location of paint tube (Figure 2, Item 15 or Figure 3, Item 41) is not preventing head rotation.</p> <p>Check air control hose is not damaged.</p>
Rotating head does not spin by hand.	Airmotor seized due to lack of lubrication.	Disassemble PIPECOATER tool and replace or service motor.
Rotating head spins too slowly.		<p>Check air supply to control gun (see 1.0).</p> <p>Check air control hose for damage. Replace if necessary.</p> <p>Check condition of exhaust air sintered filters on control gun. Disassemble / clean / replace / Reassemble.</p>

## PIPECOATER-I, PIPECOATER-II

PROBLEM	CAUSE	REMEDY
Centering carriage does not extend fully.		<p>Lift PIPECOATER body to assist leg expansion (see 3.3 and 3.4).</p> <p>Check air supply is connected to control gun.</p> <p>Check settings of air regulator on control gun.</p> <p>Check that airhose is not damaged. Replace if necessary.</p> <p>Check for obstructions / paint build up.</p> <p>Check that bottom leg of centering carriage is straight up and down.</p>
Centering carriage does not retract when turning air valve lever to off position.		<p>Check for paint build up or obstructions to legs preventing retraction.</p> <p>Check that exhaust port on air valve lever is not blocked preventing air cylinder exhausting.</p> <p>Check air control hose for damage. Replace if necessary. With air valve lever in off position, manually close carriage ensuring carriage legs and body are clear of obstructions. Do not put fingers or hands where they can be trapped between carriage legs or PIPECOATER body. Serious injury could result!</p>
No paint flow from rotating head.		<p>Check orifice in rotating head, spray tip, Strainer, high pressure paint hose and spray gun for blockages. Also if paint has been allowed to dry on interior parts, disassembly / cleaning / replacement and reassembly may be necessary.</p> <p>Check if airless spray pump is operating correctly. Follow separate manufacturers instructions.</p>
Insufficient paint flow from rotating head.		<p>Pressure / volume output of airless pump too Low. Adjust pressure input to spray pump and use correctly sized airless spray pump (see 1.0).</p>
Insufficient paint deposit on pipe internal.	Speed of pull of PIPECOATER through pipe too fast.	<p>Try slower rate.</p>
Too much paint deposit on pipe internal, resulting in paint running to bottom of pipe internal.	Speed of pull through pipe too slow.	<p>Try faster pull rate.</p> <p>Spray tip size too large for type of coating used.</p> <p>Spray tip worn, disassemble and replace.</p> <p>Too high pressure setting on airless pump. Reduce air input pressure to pump to reduce paint output pressure.</p>
Air leakage on air control hose couplings.		<p>Replace O-ring seals on air control hose.</p>

## PIPECOATER-I, PIPECOATER-II

### 6.0 SPARE PARTS

#### 6.1 PIPECOATER-I Tool, less Hoses and Gun. (See Figure 2.).....71024

Item	Description	Art.nr.
01)	Hub .....	71101
02)	Impeller.....	71102
03)	Cage .....	71103
04)	Motor end .....	71104
05)	Locking screw.....	71105
07)	Tube .....	71107
06)	Air motor .....	71106
08)	Screw .....	71108
09)	Cylinder .....	71109
10)	O-ring (34.2 x 3.0).....	71110
11)	Coupling .....	71111
12)	O-ring (34.2 x 3.0) .....	71112
13)	Strainer complete .....	71113
13a)	Strainer .....	71114
13b)	Nylon ring .....	71115

14)	Spray tip (standard 0.026")	
	Flow control tip 0.018" orifice .....	71015
	Flow control tip 0.021" orifice .....	71016
	Flow control tip 0.026" orifice .....	71017
	Flow control tip 0.031" orifice .....	71018
	Flow control tip 0.036" orifice .....	71019
	Flow control tip 0.043" orifice .....	71020
15)	Paint tube .....	71117
15a)	Nipple .....	71118
16)	Leg with wheel .....	71119
17)	Leg (only) .....	71120
18)	Bearing .....	71121
19)	Pin .....	71122
20)	Screw .....	71123
21)	Nut .....	71124
22)	Shaft .....	71125
23)	Bearing .....	71126
24)	Wheel .....	71127
25)	Ring .....	71128
	Wheel kit for PIPECOATER-I.....	71129
	Set includes:	
	shaft.....	71125
	bearings.....	71126
	wheel.....	71127

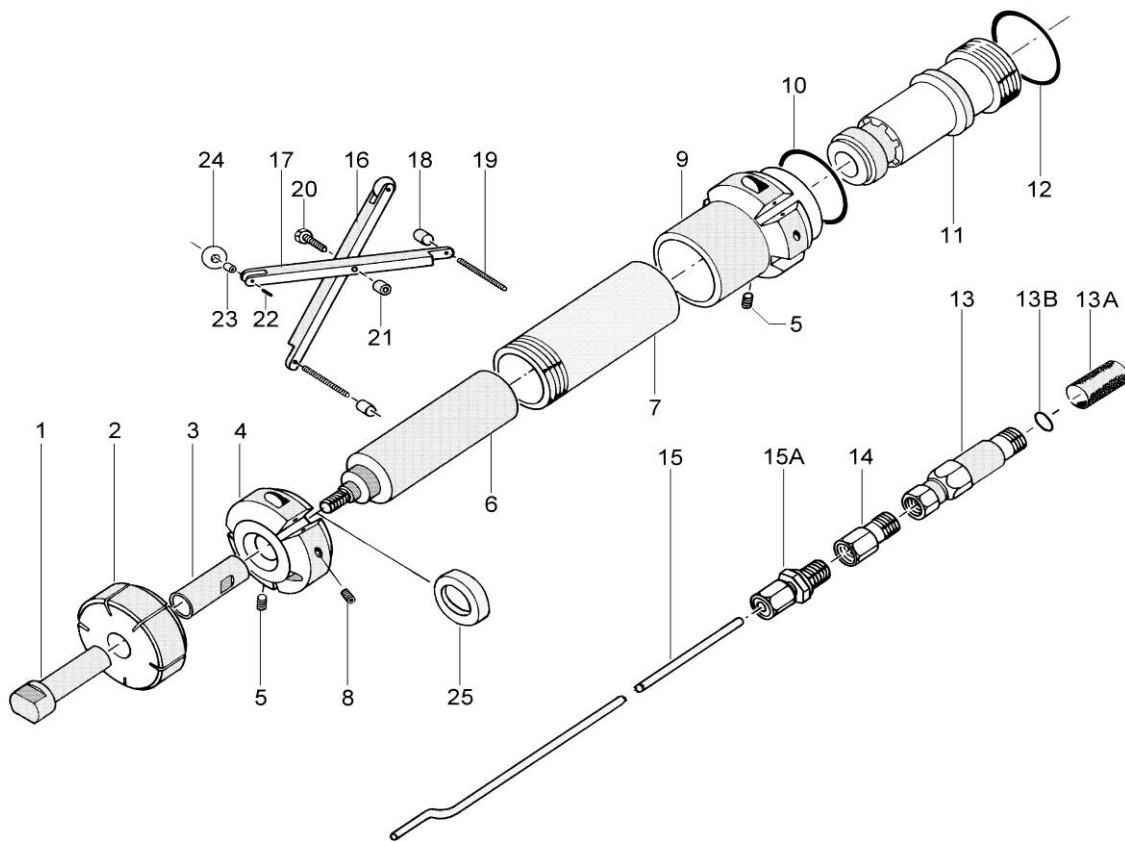

Figure 2

## PIPECOATER-I, PIPECOATER-II

### 6.2 Control gun assembly (see Figure 1) ..... 71213

Item	Description	Art.nr.
01)	Gauge .....	71214
02)	Air regulator .....	71215
03)	Connection .....	71216
04)	Bushing .....	71217
05)	Coupling .....	71218
06)	Knob .....	71219
07)	Bracket .....	71220
08)	Bolt .....	71221
09)	3-way valve .....	71222
10)	Locking ring .....	71223
11)	Tightening ring .....	71224
12)	O-ring ( 22.1 x 1.6 ) .....	71225
13)	O-ring ( 22.1 x 1.6 ) .....	71226
14)	Housing .....	71227
15)	Silencer .....	71228
--)	O-ring ( 8.1 x 1.6 ) .....	71229
--)	O-ring ( 8.1 x 1.6 ) .....	71230

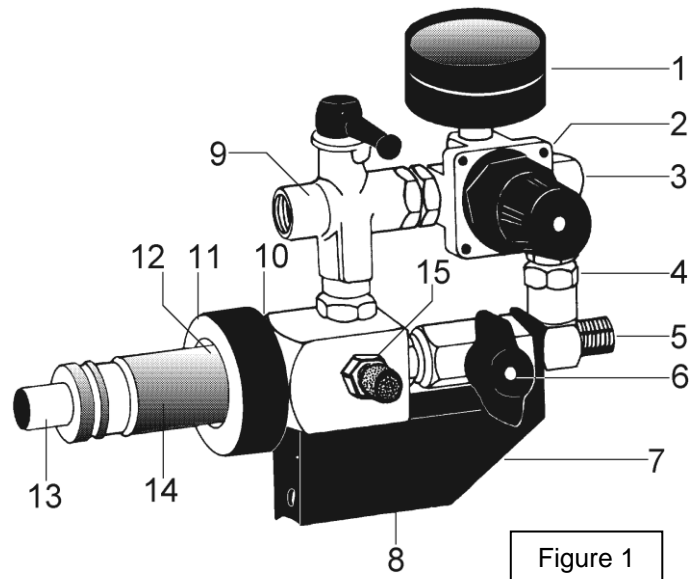

Figure 1

### 6.3 PIPECOATER-II Tool, less Hoses and Gun (see Figure 3, page 8) .... 71025

01)	Hub nut .....	71145
02)	Head, front .....	71146
03)	Head, rear .....	71147
04)	Hub .....	71148
05)	Flange .....	71149
06)	Casing .....	71150
07)	Key .....	71151
08)	Air motor, complete .....	71152
09)	Motor housing .....	71153
10)	O-ring ( 37.10 x 1.60 ) .....	71154
11)	O-ring ( 79.50 x 30.00 ) .....	71155
12)	O-ring ( 44.20 x 30.00 ) .....	71156
13)	O-ring ( 20.22 x 3.53 ) .....	71157
14)	Rod .....	71158
15)	Nut .....	71159
16)	Piston .....	71160
17)	Rod .....	71161
18)	Cylinder .....	71162
19)	Cover .....	71163
20)	Nut .....	71164
21)	O-ring ( 12.10 x 1.60 ) .....	71165
22)	O-ring ( 7.10 x 1.60 ) .....	71166
23)	Air tube, 288 mm ( 11.34" ) .....	71167
24)	Air tube, 150 mm ( 5.91" ) .....	71168
25)	Air tube, 310 mm ( 12.20" ) .....	71169
26)	Socket .....	71170
27)	Pin .....	71171
28)	Plate .....	71172
29)	Nut .....	71159
30)	Screw .....	71173
31)	Tube .....	71174
32)	Connection body .....	71175
33)	Inner arm .....	71176
34)	Outer arm .....	71177
35)	Wheel .....	71178
36)	Screw .....	71179
37)	Plate .....	71180
38)	Screw .....	71181
39)	Bushing .....	71182
40)	Bushing .....	71183
41)	Paint tube .....	71184
42)	T-piece .....	71185
43)	Spray tip ( standard 0.036" ) Flow control tip 0.018" orifice .....	71015
	Flow control tip 0.021" orifice .....	71016
	Flow control tip 0.026" orifice .....	71017
	Flow control tip 0.031" orifice .....	71018
	Flow control tip 0.036" orifice .....	71019
	Flow control tip 0.043" orifice .....	71020
44)	Strainer housing, complete .....	71187
45)	Strainer .....	71188
46)	Cover .....	71189
47)	Nut .....	71190
48)	Nylon ring .....	71191
	Rotating head for PIPECOATER-II ..	71192
	Set includes: 2) Front head ....	71146
	3) Rear head ....	71147
	4) Hub .....	71148
	Wheel kit for PIPECOATER-II .....	71193
	Set includes: 38) Screw .....	71181
	39) Bushing .....	71182
	35) Wheel .....	71178
	37) Plate .....	71180
	47) Nut .....	71190

# PIPECOATER-I, PIPECOATER-II

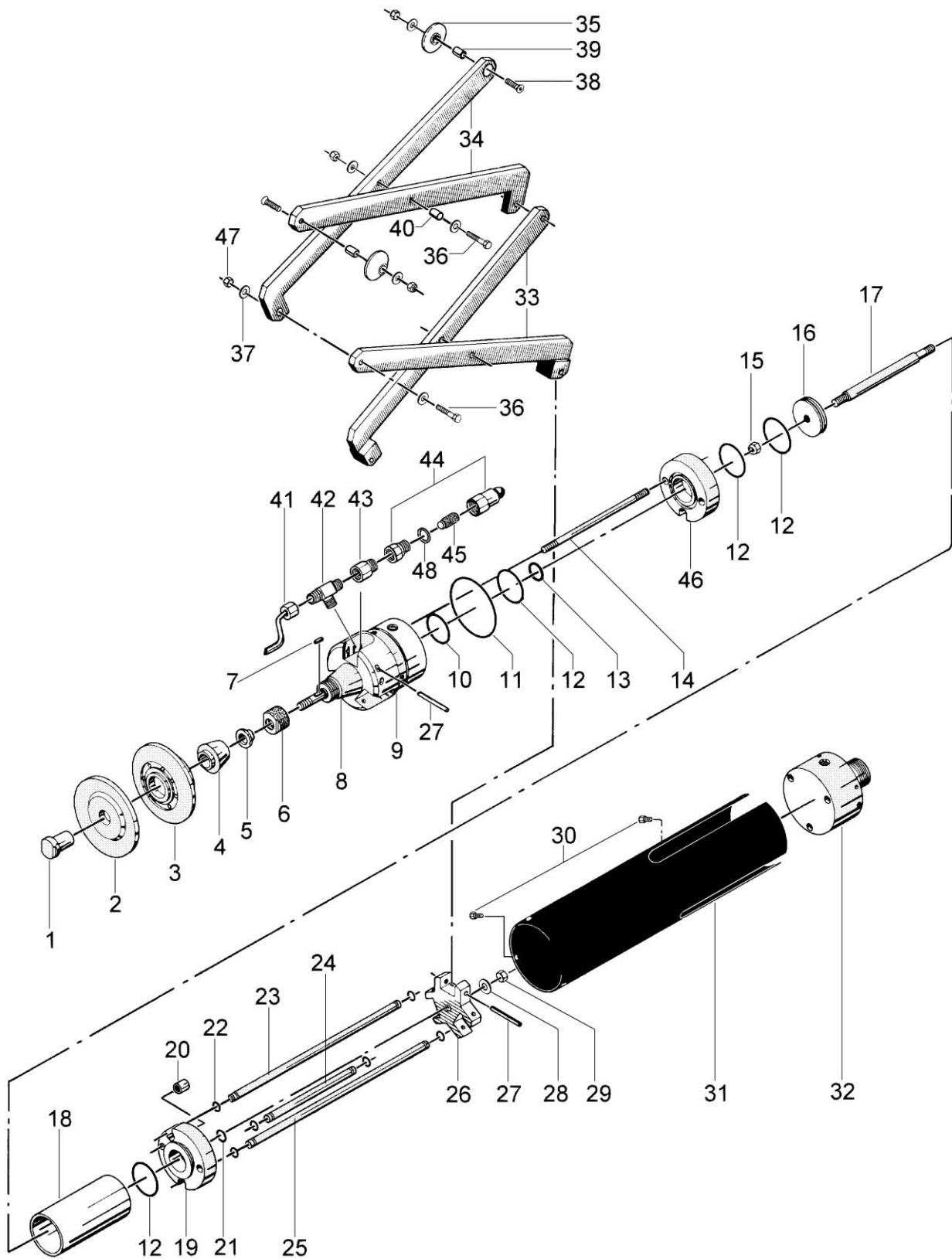

Figure 3

## PIPECOATER-I, PIPECOATER-II

### 6.4 PIPECOATER-I Air Motor .....71106 (see Figure 4)

Item	Description	Art.nr.
01)	Casing .....	71130
02)	Ball bearing .....	71131
03)	Spacer .....	71132
04)	Front plate .....	71133
05)	Key .....	71134
06)	Rotor .....	71135
07)	Blade .....	71136
08)	Cylinder .....	71137
09)	Roll pin .....	71138
10)	Rear plate .....	71139
11)	Ball plate .....	71140
12)	O-ring ( 16.1 x 1.6 ) .....	71141
13)	Spacer .....	71142
14)	Snap ring .....	71143

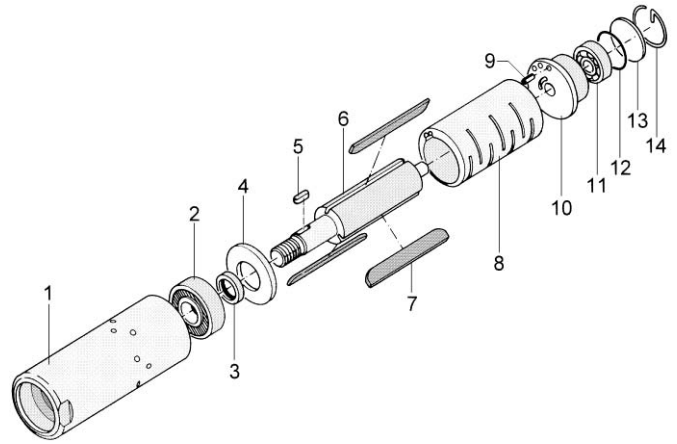

Figure 4

### 6.5 PIPECOATER-II Air Motor ..... 71152 (see Figure 5)

01)	Flange .....	71149
02)	Felt ring .....	71194
03)	Casing .....	71150
04)	Needle bearing .....	71195
05)	Spacer .....	71196
06)	Snap ring .....	71197
07)	Bearing .....	71198
08)	Spacer .....	71199
09)	Ball bearing .....	71200
10)	Key .....	71151
11)	Spindle .....	71201
12)	Cylinder setter .....	71202
13)	Ball bearing .....	71203
14)	Front plate .....	71204
15)	Roll pin .....	71205
16)	Cylinder .....	71206
17)	Rotor .....	71207
18)	Blade .....	71208
19)	Rear plate .....	71209
20)	O-ring ( 25.1 x 1.6 ) .....	71210
21)	Spacer .....	71211
22)	Snap ring .....	71212

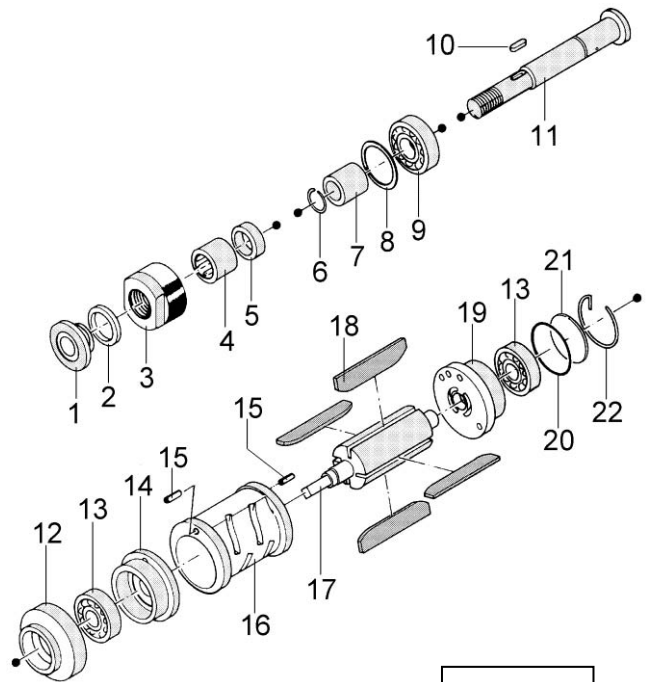

Figure 5



## **BLASTRITE GROUP**

### **Blastrite Gauteng**

Cnr of Brammer and Power Street  
Germiston  
1401

Tel. : + 27 11 8427000

Fax : + 27 11 8456456

E-mail : sales@blastrite.com

Web : www.blastrite.com

### **Blastrite Durban**

Cnr Maydon Wharf and Bayhead Rd  
Maydon Wharf  
4057

Tel. : + 27 31 2058366

Fax : + 27 31 2058367

E-mail : sales@blastrite.com

### **Blastrite Cape Town**

Bay Rd, Ben Schoeman Dock  
Cape Town Harbour  
Cape Town  
8000

Tel. : + 27 21 421 7178

Fax : + 27 21 425 2486

E-mail : sales@blastrite.com

### **Blastrite Rustenburg**

C/O Waterval Refinery  
Rustenburg Platinum Mines  
0300

Tel. : + 27 14 5911000

Fax : + 27 14 5911284