

# OWNER'S MANUAL

## PIPECOATER-III /125 /300 /900 INTERNAL PIPE PAINTING TOOL

### IMPORTANT WARNING FOR SAFER BLAST CLEANING

1. Use protective equipment: Abrasive-resistant clothing, safety shoes, leather gloves, ear protection, CE-approved air-fed helmet. Air for helmet must be supplied by a breathing air compressor or through a helmet air filter.
2. Check for possible silicosis hazards. Avoid dust.
3. Do not blast with damaged or worn equipment.
4. Point nozzle only at area being cleaned.
5. Use only proper dry and well-screened abrasives specifically intended for blasting.
6. Keep unprotected workers out of the blast area.
7. Before blasting:
  - Check fittings and hose for wear.
  - Safety-wire couplings together.
  - Check helmet filters and air supply.
  - Check pop-up valve for alignment.
  - Test remote controls.
  - Make sure blast machine is adequately grounded.
8. Do not weld on blast machine, this voids approval.
9. Do not substitute Blastrite parts or modified equipment in any way.



Servicing your blasting  
and painting needs

08600 BLAST  
sales@blastrite.co.za

 [www.blastrite.com](http://www.blastrite.com)

## PIPECOATER-III

**1.0 INTRODUCTION:** PIPECOATER tools are designed to coat the inside of pipe or tubing without the need to rotate pipe or tubing and to apply an even paint film thickness throughout. Generally, any type of coating may be used in this tool that can be airless sprayed. To obtain the best possible production, one man should operate the Paint Spray Gun while another man pulls the tool through the pipe or tubing.

**1.1 NOTE:** BE SURE TO CHECK WITH THE COATING MANUFACTURER OR SUPPLIER ON THE SIZE SPRAY TIP TO BE USED FOR APPLYING THE TYPE OF COATING SPECIFIED. SPRAY TIP SIZES USED ON PIPECOATER ARE NORMALLY LARGER THAN TIP SIZES USED FOR HAND SPRAYING APPLICATIONS. IMPROPER SPRAY TIP MAY EFFECT SPEED AND PAINT THICKNESS. THE PIPECOATER-III IS SUPPLIED WITH A .042 SPRAY TIP AS STANDARD. ANY NORMAL AIRLESS PAINT SPRAY PUMP MAY BE USED WITH THE PIPECOATER TOOLS, HOWEVER, THE MINIMUM PRESSURE RATIO SHOULD BE 30:1. FOR BEST RESULTS, USE AN AIRLESS PUMP WITH A RATIO OF 45:1 AND A CAPACITY OF 2.5 U.S. GALLONS PER MINUTE. SPRAY TIP IS LOCATED IN PAINT FEED TUBE ASSEMBLY ON THE PIPECOATER TOOL.

**1.2** Air requirement for PIPECOATER is max 22 CFM at 95 to 100 psig (600 Litre/ Min at 7 BAR). PIPECOATER-III /125 is designed to coat inner diameters from 3" to 5" (76mm to 125mm). PIPECOATER-III /300 handles 5" to 12" (170mm to 300mm). Finally PIPECOATER-III /900 handles 12" to 35" (300mm to 900mm). The parts of the PIPECOATER-III /300 & PIPECOATER-III /900 are highly interchangeable. Further, the carriage systems are exchangeable with our PIPEBLAST equipment i.e. CIRCLEBLAST & SPINNERBLAST.

### IMPORTANT WARNING

**HIGH PRESSURE DEVICE: HIGH PRESSURE CAN CAUSE SERIOUS INJURY. SAFETY PRECAUTIONS SHOULD BE TAKEN WHILE SERVICING OR OPERATING HIGH PRESSURE EQUIPMENT.**

**A.** Before operating any part of the PIPECOATER system, be sure to check all fittings and connections for tightness. Immediately replace any damaged or worn parts.

**B.** Use only high pressure hose and fittings designed for use with this equipment. Do not substitute any parts as it will void warranty and may be unfit for this application.

**C.** Never exceed specified airless pump or compressed air pressures.

**D.** Keep hands clear of centering legs to prevent injury.

**E.** Before making any adjustments, repairs, etc., shut-off airless pump and air compressor. Release fluid pressure from all lines.

**F.** If disassembled from system, never point paint spray gun at any person. The high velocity paint is dangerous.

**G.** Always engage spray gun safety lever when gun is not in use.

**H.** Refer to Airless Pump Instruction Sheet for additional safety precautions.

**I.** Always maintain a distance of 10 feet from rotating head while paint is flowing.

**2.0 INSTALLATION:** Connect high pressure paint hose to spray gun connector and to PIPECOATER paint hose fitting. Check that correct spray tip is in place and the in-line strainer is clean and in good condition. Tighten all high pressure paint hose fittings with a wrench.

**2.1** Attach Air Supply Hose to PIPECOATER air inlet. Hose is purchased separately in lengths to suit specific applications. Various lengths may be connected together to obtain desired overall length. Airless spray pump performance and paint hose distance capability must be considered with regard to pressure drop in paint hose.

**2.2** Regulation of air pressure and air flow is not included in the PIPECOATER-III package and must be arranged separately by customer.

**2.3** Connect high pressure paint hose from airless pump spray gun. Follow airless pump manufacturers instructions on setting up spray pump. Check all connections for tightness.

## PIPECOATER-III

### IMPORTANT WARNING

**TURN ON AIR COMPRESSOR AND CHECK PRESSURE. DO NOT EXCEED 100 PSIG (7 BAR).**

**2.4** Connect high pressure hose from the spray gun to PIPECOATER unit.

**2.5** Unit is now ready for test and operation. Desired quality and thickness of coating must be achieved by trial & error method. Vary with air supply (head rotating speed), retraction speed, and paint outlet pressure or flow control tip to achieve desired quality. Operation is explained in next chapter.

---

**3.0 OPERATION:** Before starting actual painting, it is advisable to operate the PIPECOATER without paint in order to become familiar with the handling of the unit.

**3.1** Turn on the air supply to check the spin of the rotating head and turn off again.

**3.2** Set the Carriage to the correct diameter size. It may be necessary to choose the diameter a bit smaller than the actual pipe diameter to be able to smoothly retract when approaching bends or protrusions in pipe. When viewing the PIPECOATER-III /900 in the pipe, the carriage should appear in the shape of a "Y".

**3.3** At this point, airless spray pump should be checked for tight fittings and proper pressure setting.

**3.4** Before inserting PIPECOATER into pipe, position rotating head inside a container and squeeze spray gun trigger. When satisfied with paint flow, pipe spraying may begin.

**3.5** Check pipe interior to ensure that it is clean and ready for coating.

**3.6** Insert PIPECOATER into pipe and check proper positioning of legs when using model /900. Push PIPECOATER through pipe until rotating head is flush with the pipe edge on the opposite end. Always pull PIPECOATER through pipe. Avoid pushing tool back as carriage wheels will damage wet coating, Re-check carriage to be sure carriage can be pulled at a smooth and steady rate.

**3.7** Turn on air supply to spin rotating head. Squeeze spray gun trigger to begin paint flow. Release trigger immediately if carriage movement is interrupted. It is critical that the operator pulling the PIPECOATER hose move the tool through pipe at even rate to avoid excessive paint thickness. Speed

of tool movement varies with pipe diameters. Small pipes can be painted faster than larger pipes. If two or more coats are desired, allow each coat to dry sufficiently prior to applying the next coat. Refer to paint manufacturers instructions for accurate drying time.

**3.8** At the exit end of pipe, furnish a shield to capture overspray as tool leaves the pipe. Use extreme care when removing PIPECOATER from end of pipe. Be sure no one is within 10 feet of rotating head except the operator. Release spray gun trigger and shut-off air supply to rotating head when tool is removed from pipe.

**3.9** Turn off air compressor and relieve all fluid pressure from the system including airless spray pump.

---

### 4.0 MAINTENANCE:

**4.1** When painting is finished, promptly clean the PIPECOATER carefully. Do not allow paint to dry in any of the internal PIPECOATER or spray gun parts. Place rotating head in a container and run solution through paint hose. Also turn on air supply for rotating head to allow solvent to flush out spray gun, paint hose, spray tip and rotating head. When clear solvent is evident on the rotating head, tool has been cleaned sufficiently. Use only cleaning solvents that are recommended by the paint manufacturer.

### IMPORTANT WARNING

**NEVER SUBMERGE PIPECOATER TOOLS IN ANY TYPE OF SOLVENT. DAMAGE WILL OCCUR TO GASKETS AND SEALS.**

**4.2** Remove strainer housing, disassemble and clean strainer with solvent. Never allow paint to dry anywhere in the system.

**4.3** Remove rotating head and clean internal cavity of disc with solvent. Any build up of paint will have an adverse effect on uniform paint flow.

**4.4** Lubrication of the PIPECOATER is important. Daily, supply 5 to 10 drops of lightweight oil through the air inlet on the PIPECOATER. If air compressor is fitted with an oil mist lubricator, be sure the oil cup is full of lightweight oil (SAE 10, Mobile Spindle Oil No. 1, Shell Spindle Oil 60 or equivalent).

**4.5** Follow manufacturers instructions on cleaning airless spray pump.

## PIPECOATER-III

### 5.0 TROUBLESHOOTING

PROBLEM	CAUSE	REMEDY
Rotating head does not spin when air is applied.		<p>Check air supply is connected to PIPECOATER.</p> <p>Check that location of paint tube or other obstacles are not preventing head rotation.</p> <p>Check air supply pressure.</p>
Rotating head does not spin by hand.	Airmotor seized due to lack of lubrication.	Disassemble PIPECOATER tool and replace or service air motor.
Rotating head spins too slowly.		<p>Check air supply capacity.</p> <p>Check air supply hose for damage. Replace if necessary.</p>
No paint flow from rotating head.		<p>Check rotating head, spray tip orifice, Strainer, high pressure paint hose and spray gun for blockages. Also if paint has been allowed to dry on interior parts, disassembly / cleaning / replacement and re-assembly may be necessary.</p> <p>Check if airless spray pump is operating correctly. Follow separate manufacturers instructions.</p>
Insufficient paint flow from rotating head.		Pressure / volume output of airless pump too Low. Adjust pressure input to spray pump and use correctly sized airless spray pump.
Insufficient paint deposit on pipe internal.	Speed of pull of PIPECOATER through pipe too fast.	Try slower rate.
Too much paint deposit on pipe internal, resulting in paint running to bottom of pipe internal.	Speed of pull through pipe too slow.	<p>Try faster pull rate.</p> <p>Spray tip size too large for type of coating used.</p> <p>Spray tip worn, disassemble and replace.</p> <p>Too high pressure setting on airless pump. Reduce air input pressure to pump to reduce paint output pressure.</p>
Air leakage on air control hose couplings.		Replace O-ring seals on air control hose.

## PIPECOATER-III

### 6.0 SPARE PARTS PIPECOATER-III WITH CARRIAGE FOR PIPES 76-125 mm / 3"-5" ID

ART.NR.	MODEL	DESCRIPTION
		<b>All (*)-marked items are fully interchangeable with relevant parts of: Pipecoater-III with carriage for pipes 125-300 mm (5"-12") Pipecoater-III with carriage for pipes 300-900 mm (12"-35")</b>
73010	PIPECOATER-III/125	<b>PIPECOATER-III</b> complete unit with centering collars for pipes with ID: 76 - 125 mm ( 3" - 5" )
1) 73100	*	Air motor
2) 73101	*	Axle
3) 73102	*	Nut ( M10 )
4) 73103		Rotating head ( diameter 54 mm )
5) 73104	*	Bolt ( M6 x 8 )
6) 73105	*	Aluminium housing
7) 73106		Rear end plate
8) 73107		Air tube ( 1/4" x 185 mm )
9) 73108		Nut ( 1/4" )
10) 73109		Inlet housing
11) 73110		Reduction nipple ( 1/2" x 1/4" )
12) 73111	73111	Threaded sleeve ( 1/8" x 21 mm )
13) 73112		Elbow ( 1/8" FF no.090 )
14) 73113		Coupling ( 1/8" x 8 mm )
15) 73114		Centering collars
16) 30060		Centering button set ( 4 x six button set )
17) 73115		O-ring
18) 73116		Paint tube
23) 73145	*	Filter holder
24) 73146	*	Tip Filter
25) See tip selection list on Page 8		Tip (standard 0.042")
26) 73147	*	Tip holder

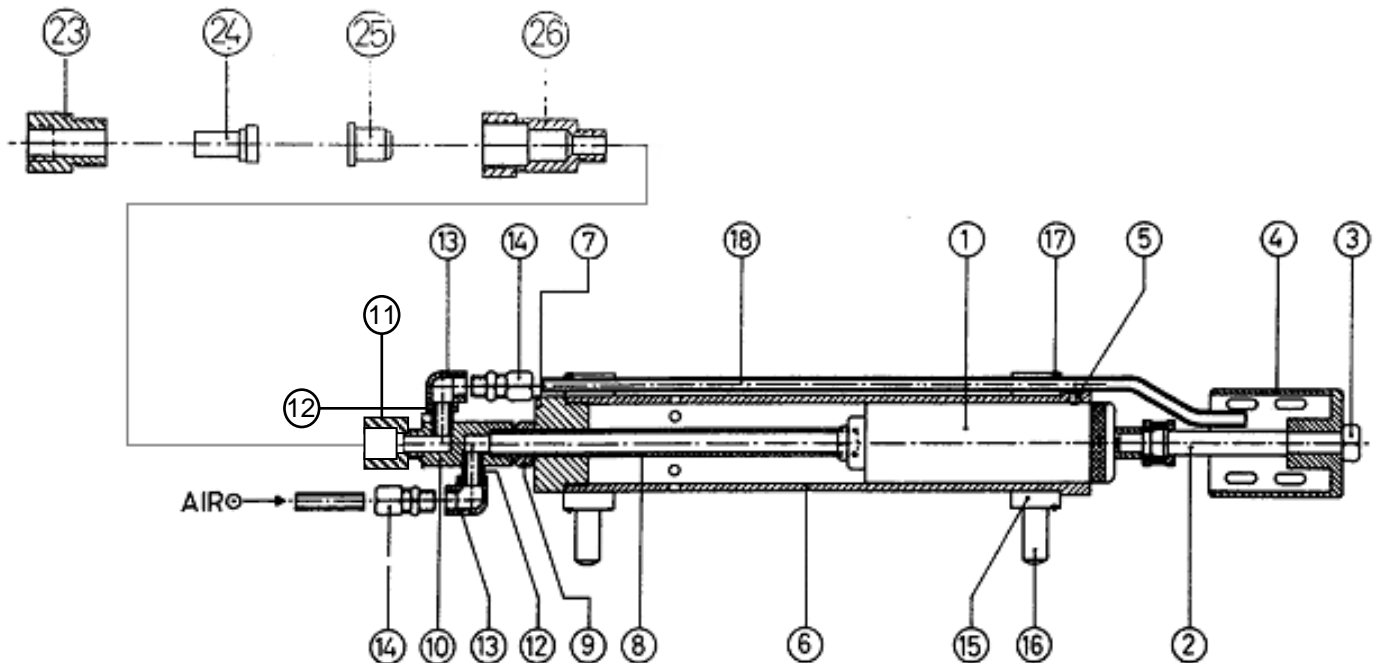

# PIPECOATER-III

## 7.0 SPARE PARTS PIPECOATER-III WITH CARRIAGE FOR PIPES 125-300 mm / 5"-12" ID

ART.NR.	MODEL	DESCRIPTION
<b>All (*)-marked items are fully interchangeable with relevant parts of:                      Pipecoater-III with carriage for pipes 300-900 mm (12"-35")</b>		
73020	PIPECOATER-III/300	<b>PIPECOATER-III</b> complete unit with centering carriage for pipes with ID: 125 - 300 mm ( 5" - 12" )
1) 73100	*	Air motor
2) 73101	*	Axle
3) 73102	*	Nut ( M10 )
4) 73120	*	Rotating head ( diameter 69 mm )
5) 73104	*	Bolt ( M6 x 8 )
6) 73105	*	Aluminium housing
7) 73121	*	Inlet housing
8) 73122	*	Coupling ( 1/4" x 8 mm )
9) 73156	*	Bolt (M10 x 10)
10) 73137	*	Rear end plate
11) 73125	*	Paint tube
12) 21761	* CCC-38/F	Quick coupling
13) 21781	* IF-14	Quick connect coupling
14) 30110	CBC - 2	Centering carriage
15) 73148	*	Lock nut
16) 30250	*	Protection sleeve threaded
17) 73140	*	Paint tube stainless steel
18) 73141	*	Nut
23) 73145	*	Filter holder
24) 73146	*	Tip filter
25) 73147	*	Tip (standard 0.042")
26) 73147	*	Tip holder

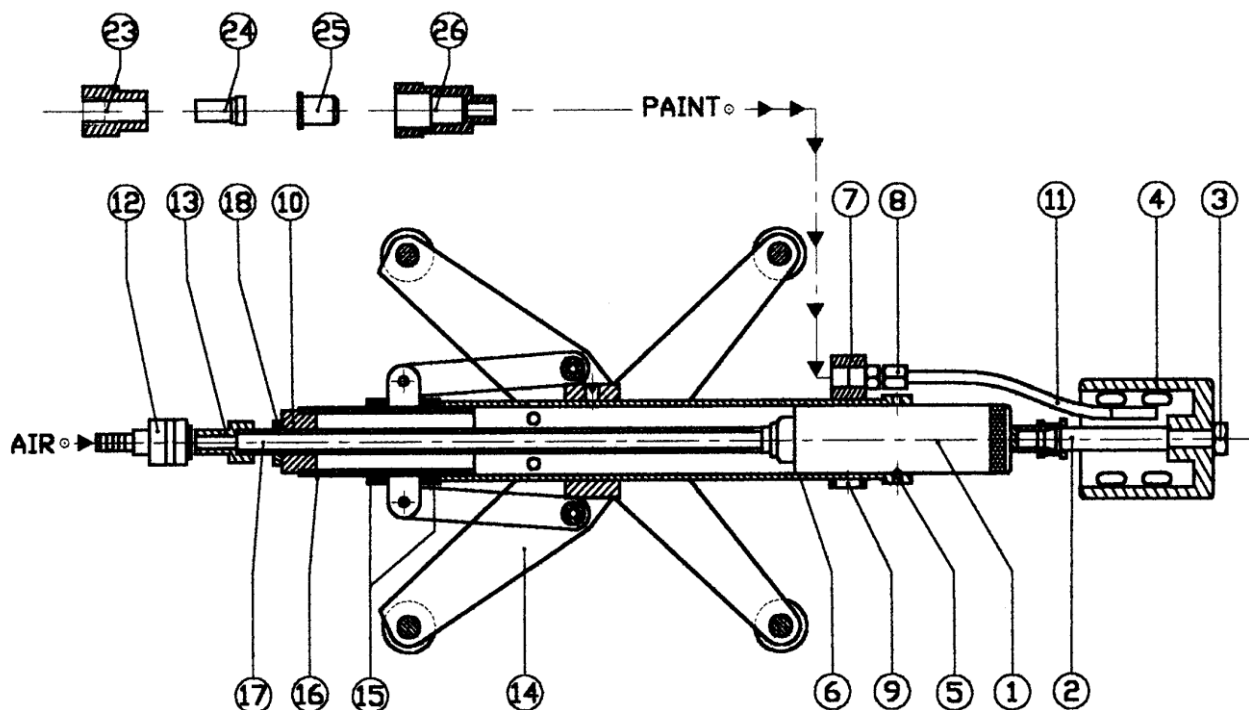

# PIPECOATER-III

## 8.0 SPARE PARTS PIPECOATER-III WITH CARRIAGE FOR PIPES 300-900 mm / 12"-35" ID

ART.NR.	MODEL	DESCRIPTION
---------	-------	-------------

All (\*)-marked items are fully interchangeable with relevant parts of:  
**Pipecoater III with carriage for pipes 170-300 mm (7"-12")**

73030	PIPECOATER-III/900	<b>PIPECOATER-III</b> complete unit with centering carriage for pipes with ID: 300 - 900 mm ( 12" - 35" )
1)	73100	* Air motor
2)	73101	* Axle
3)	73102	* Nut ( M10 )
4)	73120	* Rotating head ( diameter 69 mm )
5)	73104	* Bolt ( M6 x 8 )
6)	73105	* Aluminium housing
7)	73121	* Inlet housing
8)	73122	* Coupling ( 1/8 " x 8 mm )
9)	73136	* Bolt (M10 x 10)
10)	73137	* Rear end plate
11)	73125	* Paint tube
12)	21761	* CCC-38/F
13)	21781	* IF-14
14)	73130	Bushing
15)	30590	Centering collars
16)	30250	Protection sleeve threaded
17)	73140	Tube stainless steel
18)	73141	* Nut
19)	73142	* Aluminium tube holder
20)	73143	Nut
21)	73144	* Paint tube brass (330 mm)
22)	30570	* Arms with wheels
23)	73145	* Filter holder
24)	73146	* Tip filter
25)		Tip (standard 0.042")
26)	73147	* Tip holder
27)	30580	Set of centering legs (4 x 6 pieces)

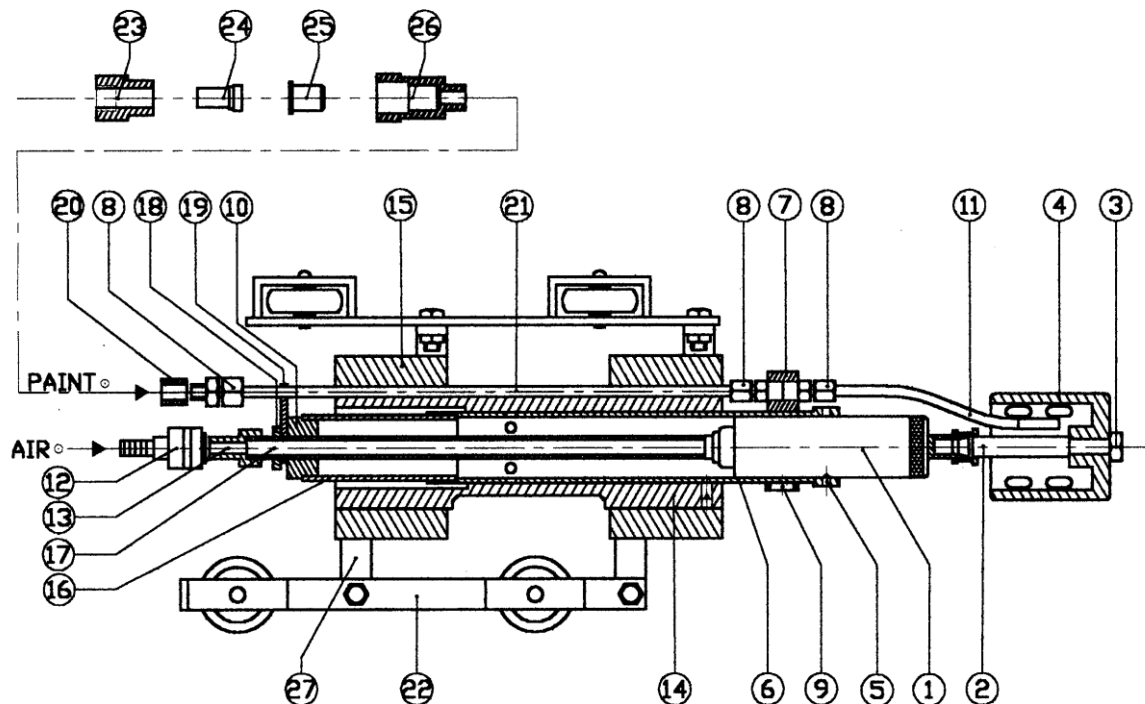



**BLASTRITE GROUP**

**Blastrite Gauteng**

Cnr of Brammer and Power Street  
Germiston  
1401  
Tel. : + 27 11 8427000  
Fax : + 27 11 8456456  
E-mail : sales@blastrite.com  
Web : www.blastrite.com

**Blastrite Durban**

Cnr Maydon Wharf and Bayhead Rd  
Maydon Wharf  
4057  
Tel. : + 27 31 2058366  
Fax : + 27 31 2058367  
E-mail : sales@blastrite.com

**Blastrite Cape Town**

Bay Rd, Ben Schoeman Dock  
Cape Town Harbour  
Cape Town  
8000  
Tel. : + 27 21 421 7178  
Fax : + 27 21 425 2486  
E-mail : sales@blastrite.com

**Blastrite Rustenburg**

C/O Waterval Refinery  
Rustenburg Platinum Mines  
0300  
Tel. : + 27 14 5911000  
Fax : + 27 14 5911284