

OWNER'S MANUAL

AIR COOLED COMPRESSED AIR AFTERCOOLERS

Series: ABAC

Type: 30, 40, 50, 65, 80, 120, 160, 200 and 250



Servicing your blasting
and painting needs

08600 BLAST
sales@blastrite.co.za

www.blastrite.com

AIR COOLED COMPRESSED AIR AFTERCOOLERS

CONTENTS

1.	FUNCTION	2
2.	INSTALLATION	2
3.	ADJUSTMENT	2/3
4.	MAINTENANCE	3/4
5.	WARNING	4
6.	CAPACITIES	5
7.	DRAWING	6

AIR COOLED COMPRESSED AIR AFTERCOOLERS

1. FUNCTION

During the compression of ambient air the suction volume is strongly minimised. How higher the required pressure, resulting in further compression, the smaller the volume will become. The present moisture in the ambient suction air will be multiplied comparable with the remaining volume of the compressed air. Due to the temperature rise as a consequence of compression, the moisture in the compressed air is present in the form of vapour. Condensation occurs as soon as the temperature of the compressed air decreases.

In order to obtain a forced cooling of the compressed air, an aftercooler is utilised. The aftercooler can be executed in a so called water cooled or air cooled version. The principle of an aftercooler is heat exchange, with as mentioned water or air as cooling media.

The air cooled compressed air aftercooler consists of a heat exchanger in the way of a so called cooling block (radiator principle). An axial fan driven with an electric or air motor blows, large quantities of ambient air over the heat exchanger. The compressed air which is in contact with a large area of heat exchanging surface, consisting of brass tubes with aluminium cooling fins, cools off.

Due to this cooling effect the moisture present as water vapour condensates and is separated by the centrifugal oil- and water separator mounted on the outlet of the aftercooler. If the selection is made according the required flow capacity the efficiency of the air cooled aftercoolers is 70 to 75%. Meaning that 70 to 75% of the present moisture is taken out of the compressed air, most of the times this is a sufficient separation rate for disturbing free blast operations.

2. INSTALLATION

- 2.1 Install the compressed air aftercooler on a sturdy and flat surface and make sure there is sufficient space around the unit for service and maintenance.
- 2.2 Make sure that the cooler is installed in such away that the ventilator get enough suction air and that there are no obstructions on the pressure side of the ventilator.
- 2.3 The aftercooler must be situated directly after the compressor in order to be most efficient. The aftercooler is placed between the compressor and air receiver if present. Duct or hose from the compressor to be connected on the inlet of the aftercooler, the entrance of the aftercooler is marked 'INLET'. Connection from the aftercooler to the air receiver is marked 'OUTLET'.
- 2.4 It's recommendable to execute the inlet of the aftercooler with a stop valve. Compressed air can then be disconnected for service and maintenance. If the aftercooler is connected to more than one compressor, each compressor needs to be executed with a non-return valve.

3. ADJUSTMENT

The compressed air driven aftercooler is executed with an air motor. This motor is connected with the outlet of the aftercooler behind the centrifugal separator by means of a service unit consisting of a compressed air filter, pressure regulator and a lubricator.

As soon as the compressor is started, the air motor will drive the axial ventilator and the aftercooler is in process. For the most efficient functioning of the aftercooler a certain amount of ambient cooling air needs to be blown over the cooling block of the unit. This quantity of cooling air is determined and in combination with the air motor's rpm The required rpm is achieved through the working pressure set at the air motor. The correct pressure and rpm is preset at our works.

The working pressure and rpm of the air motor can be adjusted with the pressure regulator of the service unit. On top of this regulator there is an adjusting knob mounted with fixation. Turning this knob clockwise the pressure and rpm gets higher, turning this knob anti clockwise the pressure and corresponding rpm gets lower.

AIR COOLED COMPRESSED AIR AFTERCOOLERS

ADJUSTMENT COMPRESSED AIR DRIVEN AIR COOLED AFTERCOOLERS, SERIES ABAC

Type	Revolutions	Pressure
	Rpm	bar
30	1440	1.6
40	1440	1.8
50	1440	1.8
65	1440	2.8
80	1440	2.8
120	1000	4.9
160	1000	4.9
200	1000	7.0
250	1000	7.0

For proper functioning and increased life time the air motor needs to be oiled with a light greasing or hydraulic oil, quality SAE 10 or likewise. This is achieved by the lubricator in the service unit of the air motor. The right amount of oil would be 2 to 4 drops per minute. On the lubricator there is an adjustment knob mounted. Turning this knob clockwise the number of droplets is increased, turning it anti-clockwise the number is minimised. Through the sight glass mounted on top of the lubricator you can count the number of droplets supplied to the compressed air driving the air motor.

4. MAINTENANCE

4.1 The cup under the filter of the service unit needs to be emptied at regular intervals. There are type's with and without automatic drain. The type without such an automatic drain the cup is executed with a bayonet connection. To empty the cup it has to be disconnected from the filter.

NOTE: The aftercooler must be depressurised, never try to remove the cup if there is pressure on the unit. It's therefor necessary to install a stop vale on the aftercooler as recommended under **2.4**.

To remove the cup push it up and turn it anti clockwise the cup can now be removed. Empty the cup and place it back to the filter unit, push it up and turn it clockwise till it's fixed. Units that are executed with an automatic drain can be emptied under

AIR COOLED COMPRESSED AIR AFTERCOOLERS

pressure. Turn the knob of the drain clockwise and the collected moisture will be pushed out by the compressed air. When the cup is empty, you can check this at the sight glass close the knob of the drain turning it anti-clockwise. This action needs to be repeated every working hour.

- 4.2** The cup under the lubricator needs permanently be filled with light hydraulic oil of above mentioned quality. The cup can only be refilled with a complete depressurised unit. This means that the recommended stop valve has to closed see **2.4**. If there is no stop valve mounted, the compressor must be stopped. The cup can be removed from the lubricator in the same as the bowl from the filter, see **4.1**.
- 4.3** With portable use of the unit, the cooling block can become contaminated. The efficiency of the aftercooler will be strongly decreased. In such a case the cooling block can be cleaned with the help of a high pressure washer. The unit have to be stopped by either the stop valve or stopping the compressor.
- 4.4** The centrifugal separator of the aftercooler is also executed with a manual drain. This drain needs to be opened, minimum once an hour to drain the collected moisture from the separator. The centrifugal separator can be executed with an automatic drain.

5. WARNING

- 5.1** Some parts of the aftercooler are pressurised, for instance the centrifugal separator, the inlet- and outlet manifold tubes and the tubes in the heat exchanger of the cooling block. These parts may not be changed or altered. Do not weld, burn, grind or execute any other mechanical works on these parts.
- 5.2** This also applies to the service unit of the air motor. Keep this unit in perfect condition and prevent damage to the connecting couplings and hoses of this system.
- 5.3** Make sure that with a running ventilator no objects can pass the protection grid of the ventilator, as this can severely damage the ventilator or air motor.
- 5.4** Use for the connections between the compressor, aftercooler and air receiver, only approved air hose corresponding with the working pressure. In case hoses with claw couplings are used secure the couplings with lock pins.
- 5.5** Give the aftercooler a thorough inspection every time it has been used and replace damaged spares and couplings of the hoses. Check moisture level in the filter of the service unit and be sure there is enough oil in the lubricator.

AIR COOLED COMPRESSED AIR AFTERCOOLERS

6. CAPACITIES in Nm³/h

		TYPE OF AFTERCOOLER								
Inlet Temp	Delta T	30	40	50	65	80	120	160	200	250
60° C	3° C	97	131	158	212	253	391	505	632	785
	6° C	148	197	248	323	392	586	778	980	1215
	9° C	219	282	360	457	561	838	1116	1402	1777
	12° C	279	375	476	620	744	1101	1493	1869	2370
80° C	3° C	92	120	155	205	250	375	500	626	780
	6° C	144	192	242	315	386	578	771	965	1205
	9° C	198	263	332	430	529	793	1058	1320	1650
	12° C	255	341	428	556	683	1023	1363	1702	2130
120° C	3° C	92	116	152	199	244	365	488	608	760
	6° C	141	185	235	305	376	562	750	940	1170
	9° C	180	240	300	390	480	720	960	1200	1500
	12° C	226	299	376	490	600	900	1200	1500	1875
160° C	3° C	72	97	123	160	197	294	392	490	611
	6° C	101	138	175	228	279	416	556	695	870
	9° C	130	177	223	291	357	533	713	890	1115
	12° C	165	223	282	367	450	672	898	1120	1400

Conditions:

Surrounding temperature : 21° C till 35° C

Working pressure : 8 bar

Relative humidity : 60 %

AIR COOLED COMPRESSED AIR AFTERCOOLERS

BLASTRITE PNEUMATIC AFTERCOOLERS

Complete with:

- Moisture separator
- Oiler and moisture separator for pneumatic motor
- Heavy duty transport frame

ART.NR.	MODEL	DESCRIPTION
Maximum operating pressure 16 bar		
50820	ABAC - 30 /Pneumatic	Capacity 3,0 cbm per minute
50825	ABAC - 40 / Pneumatic	Capacity 4,0 cbm per minute
50830	ABAC - 50 / Pneumatic	Capacity 5,0 cbm per minute
50835	ABAC - 65 / Pneumatic	Capacity 6,5 cbm per minute
50840	ABAC - 80 / Pneumatic	Capacity 8,0 cbm per minute
50845	ABAC - 120 / Pneumatic	Capacity 12,0 cbm per minute
50850	ABAC - 160 / Pneumatic	Capacity 16,0 cbm per minute
50855	ABAC - 200 / Pneumatic	Capacity 20,0 cbm per minute
50860	ABAC - 250 / Pneumatic	Capacity 25,0 cbm per minute

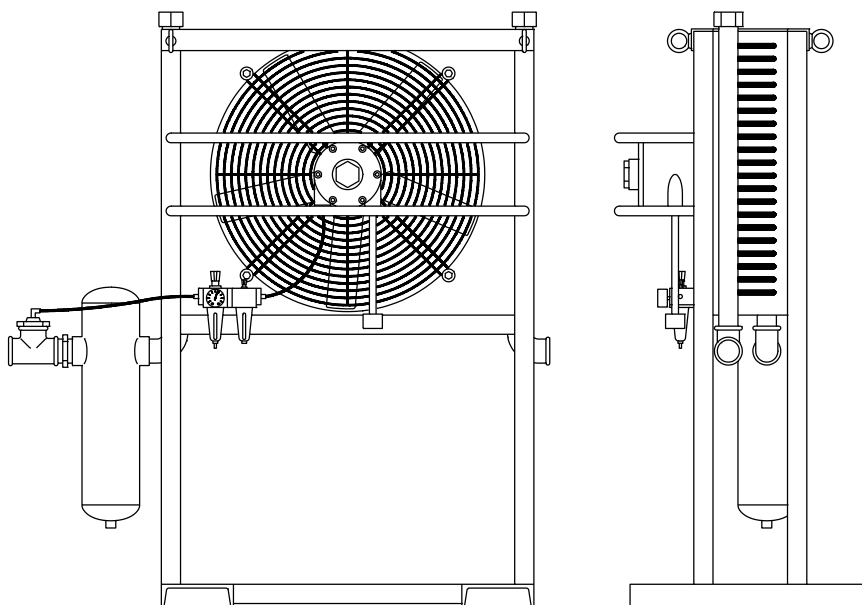

BLASTRITE GROUP

Blastrite Gauteng

Cnr of Brammer and Power Street
Germiston

1401

Tel. : + 27 11 8427000

Fax : + 27 11 8456456

E-mail : sales@blastrite.com

Web : www.blastrite.com

Blastrite Durban

Cnr Maydon Wharf and Bayhead Rd
Maydon Wharf

4057

Tel. : + 27 31 2058366

Fax : + 27 31 2058367

E-mail : sales@blastrite.com

Blastrite Cape Town

Bay Rd, Ben Schoeman Dock
Cape Town Harbour

Cape Town

8000

Tel. : + 27 21 421 7178

Fax : + 27 21 425 2486

E-mail : sales@blastrite.com

Blastrite Rustenburg

C/O Waterval Refinery
Rustenburg Platinum Mines

0300

Tel. : + 27 14 5911000

Fax : + 27 14 5911284

E-mail : sales@blastrite.com